

Intell-A-Changer



*The Power
of Change*



**MATERIALS
TRANSPORTATION
COMPANY™**

SINCE 1946

An Employee Owned Company

Bulletin ICE-1204



COMPLETE BATTERY MANAGEMENT

WHY AN INTELL-A-CHANGER:

The answer is simple. The Intell-A-Changer by MTC is the most advanced battery-changing robot on the planet. It has been designed to replace battery-changing operators, saving your company money -- possibly, a hundred thousand dollars each year.

When used in AGV applications, it completely eliminates hot shoe charging and the huge cost to set it up around the warehouse. The Intell-A-Changer returns the time required for charging to productivity time. Many applications have increased productivity by up to 25 percent without adding any additional AGVs.

Using the Intell-A-Changer with our E-Batt Battery Management system will reduce the number of batteries and chargers you need and in many cases reduce the number of chargers by 50 percent. The unit is capable of determining when a battery has finished charging, removes it from the charger slot and inserts it into a cooling slot, thus eliminating the need to have one charger per slot.

The Intell-A-Changer is not hampered by the limitations of Fast Charging. While that method may deliver 80 percent charged batteries, which only run a few hours between charges, the Intell-A-Changer delivers fully charged batteries to the vehicles when they are needed.

The first rule of "opportunity quick charge" is that you must have the opportunity and the discipline to plug in the trucks. Most companies that utilize quick charge applications must purchase additional trucks to compensate for the poor battery performance and lack of time to charge the vehicles. Not to mention the fact that a typical battery system to support a 50 truck system will use only 1500 square feet of plant space. By contrast, the same number of trucks for a park-and-charge application will take up to 3600 square feet.

The bottom line -- the Intell-A-Changer has been designed to be flexible and allows you to do more with less. That's the power of Change!



THIS IS THE FUTURE OF BATTERY CHANGING



The Intell-A-Changer is designed to change batteries in Automatic Guided Vehicles (AGVs), Laser Guided Vehicles (LGVs), and forklifts. The Intell-A-Changer makes it possible for AGVs and forklifts to stay on the floor longer.



The Intell-A-Changer automatically lines up with your forklift for a perfect battery change.

Intell-A-Changer



Traveling at a speed of 300 fpm, and with a lift speed of 45 fpm, the Intell-A-Changer will change a battery without an operator! At the start of the twenty-first century, it is undoubtedly the most efficient battery changer ever built with the ability to store batteries at multiple levels.

The MTC Intell-A-Changer is the next-generation, fully automated battery changing system that allows you to execute flawless battery changes every time. This is an all-electric changer, using no hydraulics, that utilizes an Allen-Bradley ControlLogix PLC that controls seven SEW-Eurodrive inverters and motors. Encoders inform the PLC about such things as carriage height, arm travel, and arm movements. It utilizes a laser for down-aisle position sensing.

Engineers • Designers • Manufacturers
www.mtcworldwide.com

Phone (254)298-2900 • U.S. (800)433-3110 • Canada (800)229-5988



TAKING BATTERY CHANGING TECHNOLOGY TO THE NEXT LEVEL

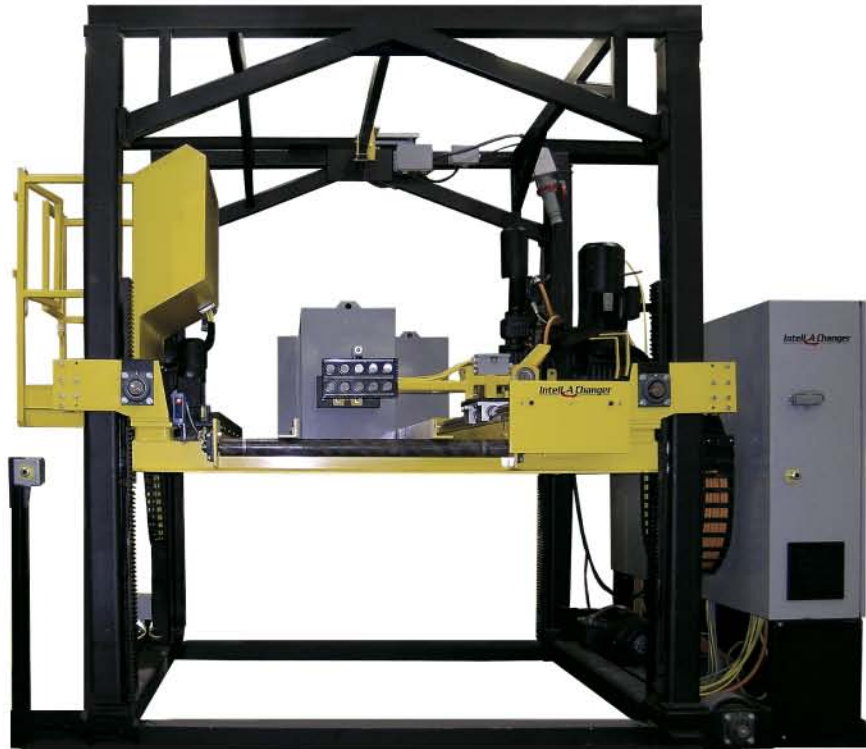

➤ MTC's all new Intell-A-Changer is the most comprehensive solution for managing batteries and cost. When combined with the E-Batt Battery Management System from Prophecy Software, the Intell-A-Changer brings the future of battery changing into focus today. This system is all about moving products safely and efficiently and with reduced manpower.

FEATURES

Totally automated battery changing

All electric drives with absolute encoders

Electro-magnetic extraction

Complete DC power management

BENEFITS

Eliminates the cost of a dedicated operator

Provides long lasting dependability and precise battery changes

Provides powerful, reliable and consistent battery attachment

- Reduces the number of batteries and chargers required
- Allows you to track performance and maintenance
- Generates reports showing all battery and charger activity

THE INTELL-A-CHANGER: THE MOST COST EFFECTIVE SOLUTION YET



↪ The “brain center” of the Intell-A-Changer: the Allen-Bradley ControlLogix PLC.



↪ Your batteries will be equipped for automatic connect and disconnect.



↪ The T-arm utilizes a worm gear electric drive to transfer the magnet from one side to the other.



↪ You can totally automate your battery room to maximize available floor space.

SEW
EURODRIVE

Intell A Changer

Engineers • Designers • Manufacturers
www.mtcworldwide.com

Phone (254)298-2900 • U.S. (800)433-3110 • Canada (800)229-5988

MTC MATERIALS
TRANSPORTATION
COMPANY™
SINCE 1946 An Employee Owned Company

Intell A Changer

Bulletin ICE-1204



***The Power
of Change***

P.O. Box 1358
Temple, Texas 76503
Phone (254) 298-2900
Fax (254) 771-0287
U.S. (800) 433-3110
Canada (800) 229-5988
www.mtcworldwide.com



**MATERIALS
TRANSPORTATION
COMPANY™**

An Employee Owned Company

Copyright 2005 Materials Transportation Company.
All rights reserved.